

DK50 4VR/50



INSTALLATION, OPERATION AND MAINTENANCE MANUAL

EN

CONTENTS

IMPORTANT INFORMATION	3
1. CE MARKING	3
2. WARNINGS	3
3. ALERT NOTICES AND SYMBOLS	4
4. STORAGE AND TRANSPORT	4
5. TECHNICAL DATA.....	5
6. PRODUCT DESCRIPTION	6
7. FUNCTION	8
INSTALLATION	12
8. USE.....	12
9. INSTALLATION	12
10. WIRING DIAGRAMS	16
11. PNEUMATIC DIAGRAM.....	18
12. FIRST OPERATION	19
OPERATION	20
13. SWITCHING THE COMPRESSOR ON	20
MAINTENANCE	22
14. MAINTENANCE SCHEDULE	22
15. MAINTENANCE.....	22
16. STORAGE	25
17. DISPOSING OF THE APPLIANCE	25
18. REPAIR SERVICE.....	25
19. SOLVING PROBLEMS.....	25

IMPORTANT INFORMATION

1. CE MARKING

Products labeled with the CE mark of compliance meet the safety guidelines (93/42/EEC) of the European Union.

2. WARNINGS

2.1. General warnings

- This Installation, Operation and Maintenance Manual is a part of the appliance and must be kept with the compressor. Careful review of this manual will provide the information necessary for correct operation of the appliance.
- The safety of operating personnel and trouble-free operation of the appliance are guaranteed only if original parts are used. Only accessories and parts mentioned in the technical documentation or expressly approved by the manufacturer can be used.
- If any other accessories or consumable materials are used, the manufacturer cannot be held responsible for the safe operation of the appliance. This guarantee does not cover damages originating from the use of accessories or consumable material other than those specified or suggested by the manufacturer.
- The manufacturer guarantees the safety, reliability and function of the appliance only if:
 - Installation, new settings, amendments, extensions and repairs are performed by the manufacturer or its representative, or a service provider authorized by the manufacturer
 - The appliance is used in accordance with this Installation, Operation and Maintenance Manual
- The manufacturer reserves all rights for the protection of its wiring diagrams, methods and names.
- Translation of Manual for Installation, Operation and Maintenance is carried out in accordance with the best knowledge. In the case of ambiguities, the Slovak version of the text prevails.

2.2. General safety warnings

The manufacturer developed and designed the equipment in such a way so that any risks were excluded if it is used according to intention. The manufacturer considers it to be its obligation to describe the following safety measures in order to exclude residual damages.

















- Operation of the appliance must be in compliance with all local codes and regulations.
- Original packaging should be kept for the return of the appliance. Only the original packaging ensures protection of the appliance during transport. If it is necessary to return the appliance during the guarantee period, the manufacturer is not liable for damages caused by improper packaging.
- Each time the appliance is used, the operator must make sure that it is functioning correctly and safely.
- The user must fully understand the operation of the appliance.
- The product is not intended for operation in areas with a risk of explosion.
- If any problem occurs during use of the appliance, the user must inform his supplier immediately.

2.3. Electrical system safety warnings

- The appliance must be connected to earth (grounded).
- Before the appliance is plugged in, make sure that the mains voltage and mains frequency stated on the appliance are the same as the power mains.
- Prior to putting into operation it is necessary to check for possible damage of the equipment and connected air and electric distributions. Damaged pneumatic and electric lines must be immediately replaced.
- Immediately disconnect the appliance from the mains (pull out mains plug) if a technical failure occurs.
- During repairs and maintenance, ensure that:
 - The mains plug is pulled out from the socket
 - Pressure pipes are vented and pressure is released from the air tank.
- The appliance must be installed by an approved, qualified technician.

3. ALERT NOTICES AND SYMBOLS

In the Installation, Operation and Maintenance Manual and on packaging and product, the following labels or symbols are used for important information:

	Attention, see instructions for use
	Caution, risk of electric shock
	Consult instructions for use
	CE mark of compliance
	Compressor is remote-controlled and may start without warning
	Caution! Hot surface
	Earth (ground) connection
	Terminal for ground connection
	Fuse
	Alternating current
	Handling mark on package – FRAGILE
	Handling mark on package – THIS SIDE UP
	Handling mark on package – KEEP DRY
	Handling mark on package – TEMPERATURE LIMITATIONS
	Handling mark on package – LIMITED STACKING
	Mark on package – RECYCLABLE MATERIAL

4. STORAGE AND TRANSPORT

The compressor is shipped in cardboard that protects the appliance from damage during transport.



Caution! For transport, always use the original packaging and secure the compressor in the upright position.



Protect the compressor from humidity and extreme temperatures during transport and storage. A compressor in its original packaging can be stored in a warm, dry and dust-free area. Do not store near any chemical substances.



Keep packaging material if possible. If not, please dispose of the packaging material in an environmentally friendly way and recycle if possible.



Caution! Before moving or transporting the compressor, release all the air pressure from the tank and hoses and drain the condensed water.

5. TECHNICAL DATA

			DK50 4VR/50	DK50 4VR/50S
Rated voltage / frequency	V / Hz		3x400/50	3x400/50
Compressor output at pressure of 6 bar	L.min ⁻¹		250	250
Compressor output at 6 bar with dryer	MD	L.min ⁻¹	200	200
	NDL		180	180
Peak compressor current	A		4.7	5.1
Maximum compressor current with dryer	A		4.8	5.2
Motor output	kW		2.2	2.2
Air tank capacity	L		50	50
Working pressure	bar		6.0 – 8.0	6.0 – 8.0
Maximum operating pressure of safety valve	bar		12.0	12.0
Noise	L _{pfA} [dB]		77	58
Mode of operation			Continuous S1	Continuous S1
Mode of operation with dryer			Continuous S1	Continuous S1
Compressor dimensions	W x L x H	mm	580x580x790	750x770x1015
Dimensions with dryer	MD	mm	580x635x790	
	NDL		580x635x790	
Weight	kg		70	128
Weight with dryer	MD	kg	81	139
	NDL		89	147
Air dryer performance				
Atmospheric dew point	MD	°C	-20	
Pressure dew point	NDL		-40	
Configuration pursuant to STN EN 60 601-1			Type B, class I.	

- Air leaving the dryer is filtered using a 5 µm filter at a minimum.

Climatic conditions during storage and transport

Temperature : -25°C to +55°C, 24 h to +70°C
 Relative air humidity : 10% to 90 % (no condensation)

Climatic operation conditions

Temperature : +5°C to +40°C
 Relative air humidity : 70%

5.1. FAD efficiency correction for differences in elevation

FAD correction table

Elevation [mamsl]	0 - 1500	1501 - 2500	2501 - 3500	3501 - 4500
FAD [l/min]	FAD x 1	FAD x 0.8	FAD x 0.71	FAD x 0.60

FAD efficiency refers to conditions at an elevation of 0 mamsl:

Temperature: 20°C
 Atmospheric pressure: 101325 Pa
 Relative humidity: 0%

6. PRODUCT DESCRIPTION

6.1. Model variations and their uses

Compressors are the source of clean, oil-free compressed air used to drive dental appliances and equipment.

Compressors models are designed for the following uses:

Dental compressors DK50 4VR/50 - are designed for independent installation in a suitable environment.

Dental compressors DK50 4VR/50/M - are designed for independent installation in a suitable environment and are equipped with an air dryer. (MD, NDL)

Dental compressors DK50 4VR/50S - are installed in cabinets with efficient noise mufflers and are suitable for use in office environments.

Dental compressors DK50 4VR/50S/M - are installed in cabinets and are equipped with air dryers. (MD, NDL)

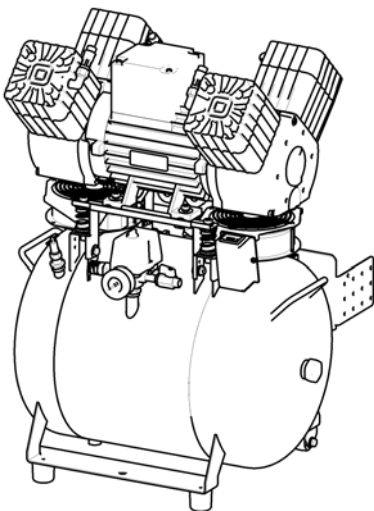

DK50 4VR/50

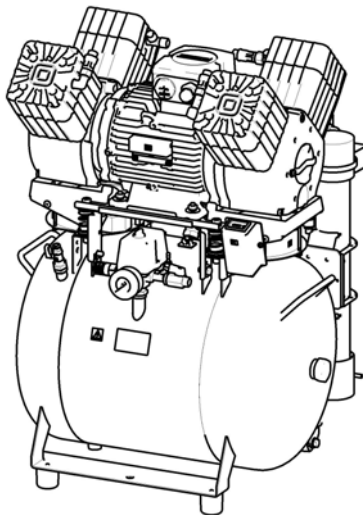

DK50 4VR/50/M

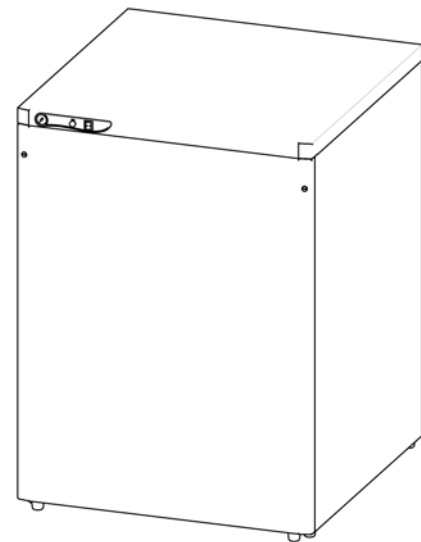

DK50 4VR/50S/M

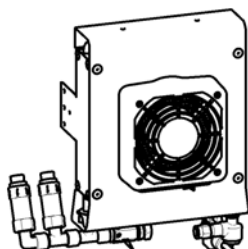

COOLER

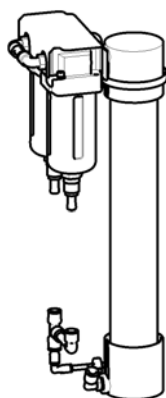

**MEMBRANE
DRYER**

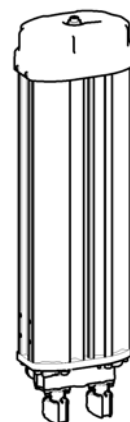

DRYER NDL



Without additional filtration equipment, the compressed air from a compressor is not suitable for the operation of breathing appliances or similar equipment.

6.2. Optional accessories

Products may be equipped with optional accessories that are not included with the basic product and must be ordered separately:

Filter regulator / set 603022106-000 /

The filter regulator filters out impurities in the compressed air down to a size of 5 μm . The use of this accessory on a compressor without a dryer partially reduces moisture content in the supplied compressed air. Filtered compressed air is suitable for use anywhere its parameters meet the stipulated requirements. The regulator ensures a supply of output air at a constant pressure (so long as the pressure value set on the regulator is not higher than the switching pressure set on the pressure switch).

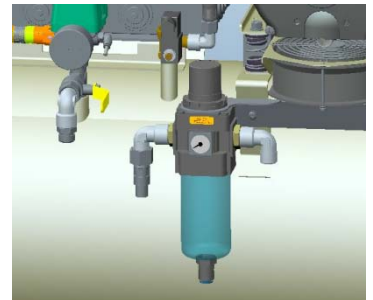

Regulator / set 603022104-000 /

The regulator ensures a supply of output air at a constant pressure (so long as the pressure value set on the regulator is not higher than the switching pressure set on the pressure switch).

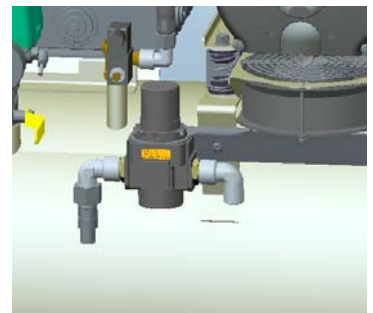

Automatic condensate drain / set 603013114-000 /

The automatic condensate drain automatically drains condensate from the compressor's air tank based on a pre-set time interval.

The drain automatically opens a solenoid valve at a pre-set time interval to drain condensate from the air tank.

- A timer is used to set the time between actuation of the solenoid valve (approximately 30 minutes).
 - The time between actuations of the solenoid valve can be adjusted to a lower value if excessive amount of condensate is generated.
- The TEST button (2) is used to check the actuation of the solenoid valve, and when pushed the solenoid valve should open (ON) and the time between actuations of the solenoid valve begins from this point.
 - The LED (1) lights up to signalize the valve is open(ON).

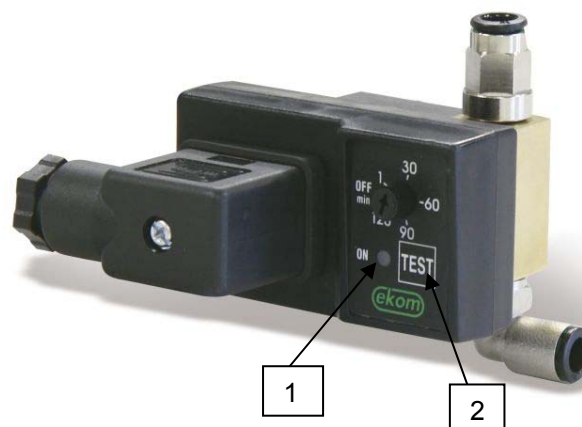
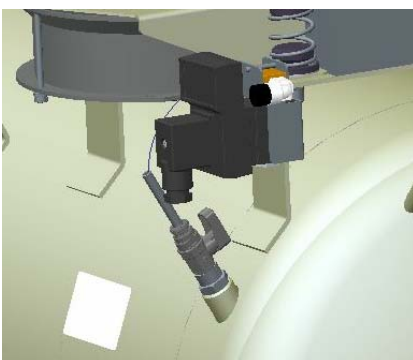

7. FUNCTION

Compressor (Fig.1)

The compressor (1) draws in air through a filter (8) and compresses it through a check valve (3) into an air tank (2). The connected apparatus draws the compressed air from the air tank until the pressure drops to a default preset level on the air-pressure switch (4) switching the compressor on. The compressor again compresses air into the nozzle until the maximum pressure is reached and the compressor switches off. Safety valve (5) prevents the pressure in air chamber from rising above the maximal allowed value. The drain valve (7) releases the condensate from the air nozzle. Compressed, dry and clean air is then ready for additional use in the air tank.

Compressor with membrane dryer (MD) (Fig. 2)

The compressor (1) draws in air through an inlet filter (8) and compresses it into a cooler (12). The air then passes through a filter (16) and micro-filter (15) into the dryer (14) with the dry and clean air passing through a check valve (3) to the air tank (2). Condensate from the filter and micro-filter is automatically released into a drainage vessel. The dryer ensures continuous drying of the compressed air. Compressed, dry and clean air is then ready for additional use in the air tank.

Compressor with NDL dryer (Fig. 3)

The compressor (1) draws in air through an inlet filter (8) and compresses it into the cooler. The air then passes through the dryer chamber (23) containing the adsorbent media where moisture is removed and then out via the check valve (3) and into the air tank (2). The adsorbent media regenerates when the drying chamber is being evacuated, always after the compressor is switched off by the pressure switch. The air is then released from the adsorption chamber via the open solenoid valve as it is evacuated using dry compressed air. Air drying occurs in one chamber while regeneration occurs in the other chamber. The mode of each chamber changes in regular cycles and the drying and regeneration processes are then performed in the alternate chamber. Compressed, dry and clean air is then ready for additional use.

The pressure switch (24) protects the dryer from damage if the compressor operates for an extended period of time at low pressure (less than 5 bar)

Compressor cabinet (Fig. 4)

The soundproof cabinet itself is compact yet allows sufficient exchange of cooling air. The fan (9) underneath the compressor aggregate and the cabinet fans (33) cool the compressor and the space inside the cabinet. The fans operate when the compressor motor is running. The cooling fans automatically start if the temperature in the cabinet reaches over 40°C, even when the compressor is not running. The fans automatically switch off once the cabinet temperature drops to around 32°C.

An indicator (34) located on the front of the cabinet indicates maintenance is needed on the compressor with the NDL dryer unit (see the Maintenance Interval chapter)



Make sure that nothing impedes the free flow of air under and around the compressor. Never cover the hot air outlet on the top back side of the case.



If placing the compressor on a soft floor such as carpet, create space for ventilation between the base and floor or the box and floor, e.g. underpin the footings with hard pads.

Fig. 1 - Compressor

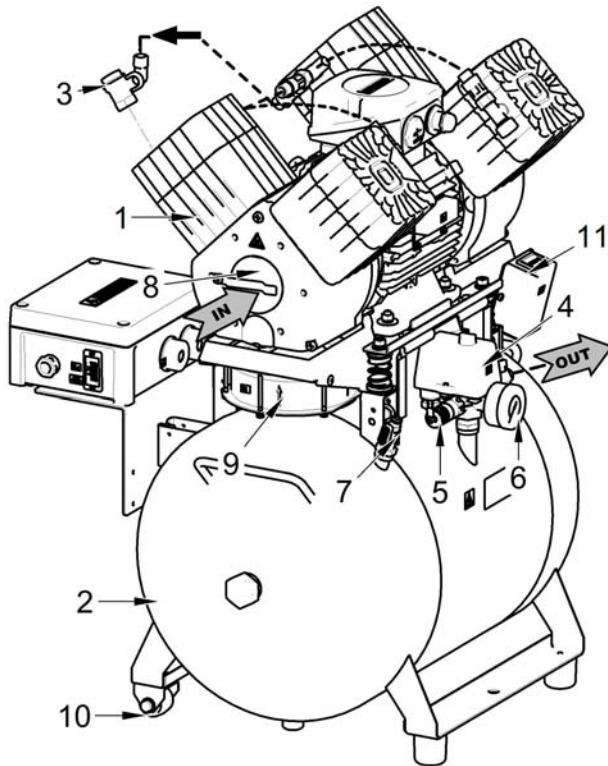

1. Compressor
2. Air tank
3. Check valve
4. Pressure switch
5. Safety valve
6. Pressure gauge
7. Condensate drain valve
8. Inlet filter
9. Compressor fan
10. Compressor wheel
11. Hour meter
12. Dryer cooler
13. Plug
14. Membrane dryer (MD)
15. Micro-filter
16. Filter
17. Check valve
18. Magnetic bracket
19. Plug
20. Condensate vessel
21. Outlet valve
22. Exhaust muffler
23. Adsorption dryer (NDL)
24. Pressure switch 2
25. Cabinet pressure gauge
26. Switch
27. all bump stop
28. Cabinet connector
29. Pressure gauge hose
30. Supporting bracket
31. Compressor wheel
32. Positioning truck
33. Cabinet fan
34. Maintenance indicator

Fig. 2 - Compressor with membrane dryer (MD)

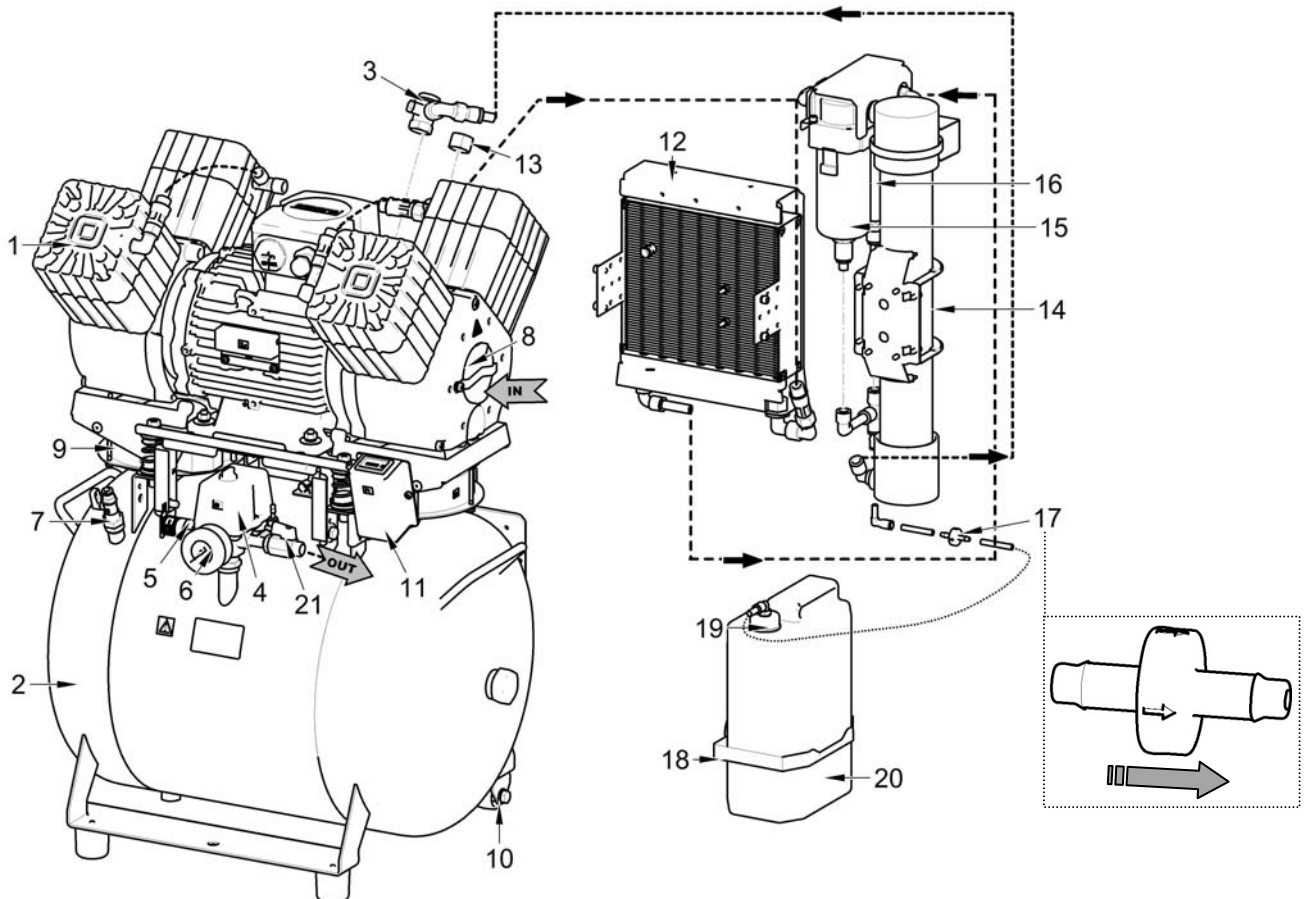

Fig. 3 - Compressor with adsorption dryer (NDL)

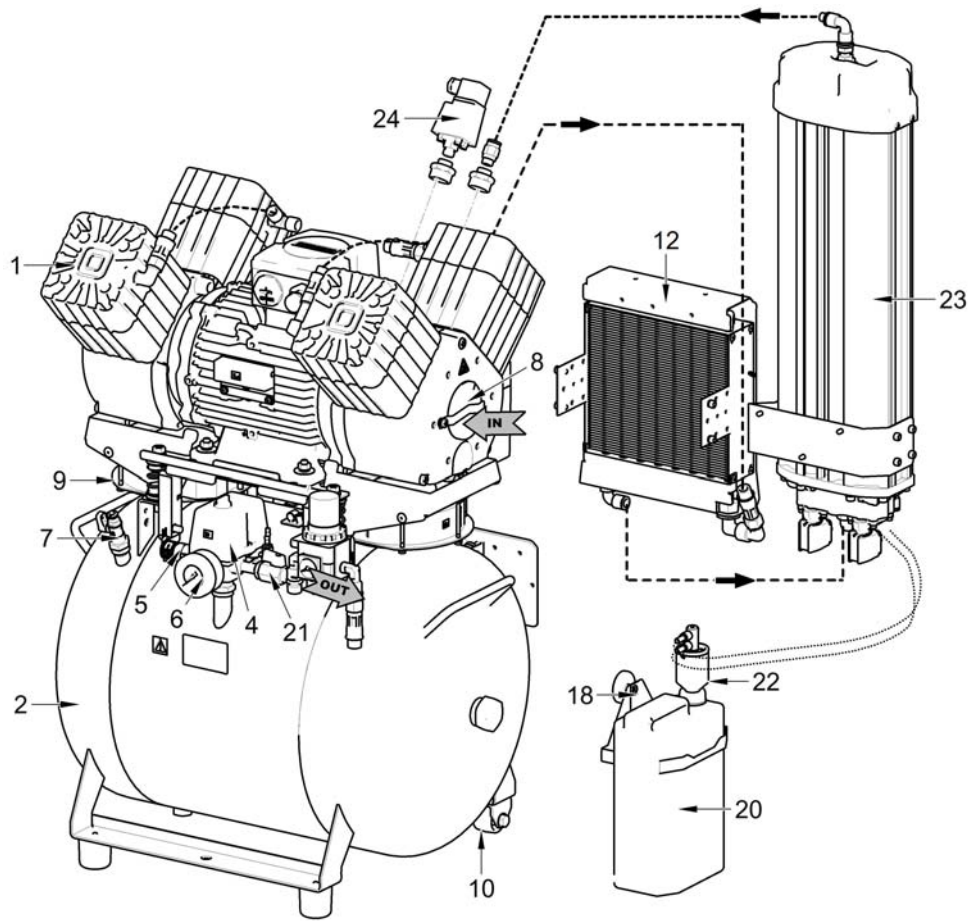
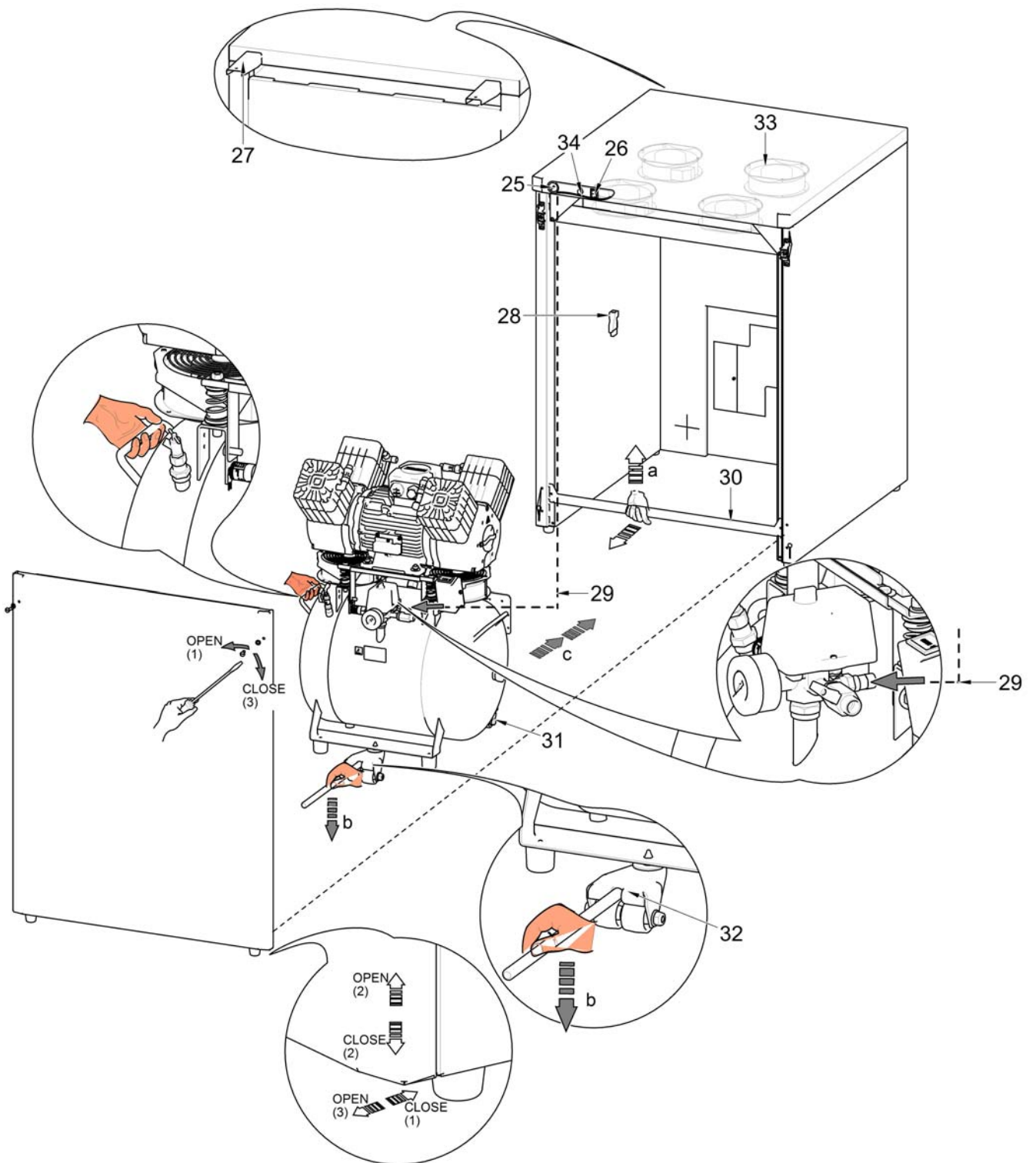

Fig. 4 - Cabinet



INSTALLATION

8. USE

- The appliance must be installed and operated in a dry, well ventilated and dust-free area where ambient temperature is within the range of +5°C to +40°C and relative air humidity does not exceed 70%. Otherwise, failure-free operation of the compressor cannot be guaranteed. The compressor must be installed so that it is accessible at all times for operation and maintenance. Please ensure that the appliance label is accessible.
- The appliance must stand on a flat, sufficiently stable base. See paragraph 5 (Technical data) when positioning or lifting the compressor.
- Compressors cannot be exposed to outdoor environments. The appliance cannot be used in moist or wet environments. Do not use the compressor in the presence of explosive gases, dust or combustible liquids.
- Before connecting the compressor to medical equipment, the supplier must confirm that it meets all requirements for its use. Refer to the technical data of the product for this purpose. When a unit is to be built-in, classification and evaluation of compatibility must be done by the manufacturer or supplier of the product to be used.
- Any use other than that described in this manual is not covered by the guarantee, and the manufacturer is not liable for any damages that may result. The operator/user assumes all risk.

9. INSTALLATION



Only qualified personnel can install and start up the appliance and train operating personnel in its correct use and maintenance. Installation and training of all operators shall be confirmed by the installer's signature on the certificate of installation.



Prior to installation, ensure that the compressor is free of all transport packaging and stabilizers to avoid any risk of damage to the product.



Caution! When in operation, the compressor is hot. Burns or fire may result if contact is made by the operator or any flammable material.



Electric cord for connection to electric mains and air hoses may not be broken. The power cord may not be exposed to pulling, pressure and excessive heat.

9.1. Placement of the compressor

Fig.5

Handling

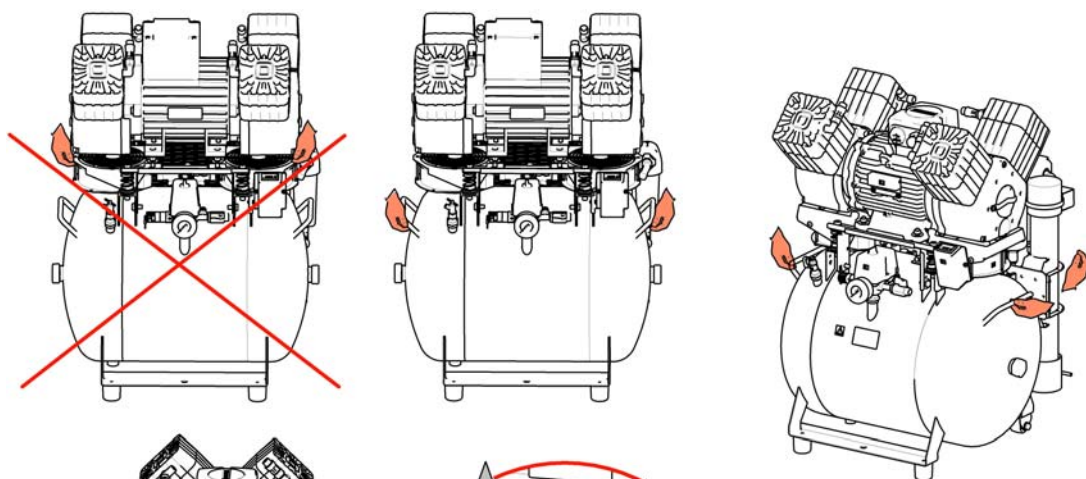

Unpacking

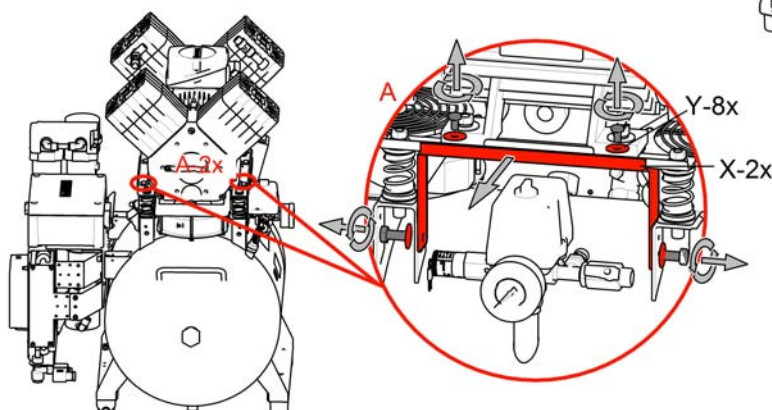

Dental compressor DK50 4VR/50 (Fig. 5)

After unpacking the equipment, position it on the floor and free it from all packing materials and remove the fixation components (X and Y) - see Detail A. Connect the outlet pressure hose to the connector on the device. Insert the mains plug into a rated outlet circuit.

Dental compressor DK50 4VR/50/M (Fig 5).

After unpacking the equipment, position it on the floor and free it from all packing materials and remove the fixation components (X and Y) - see Detail A. Connect the outlet pressure hose to the connector on the device. Insert the mains plug into a rated outlet circuit. Connect the hose(s) for the condensate drain (from the dryer, solenoid valve and condensate line) to the condensate vessel.

Cabinet-mounted dental compressor DK50 4VR/50S (Fig. 4, Fig. 5)

After unpacking the equipment, position it on the floor and free it from all packing materials and remove the fixation components (X and Y) - see Detail A. Install the 2 wall bump stops (27) on the upper rear portion of the cabinet and install in the desired location. The bump stops ensure that the cabinet is properly spaced from the wall for ventilation purposes. 2 screws must be released to install the compressor into the cabinet, then open the door to the cabinet and detach the supporting bracket (30) in the front part of the cabinet. Pass the pressure hose and mains plug from the compressor through the opening in the lower rear section of the cabinet. Connect the cabinet connector (28) to the compressor and run the mains plug through the opening in the lower rear section of the cabinet. Pick up the compressor using the handle and use the positioning truck (32) and the installed wheels (31) to position it inside the cabinet. Install the hose (29) for the cabinet pressure gauge (25) into the quick connectors on the compressor and reinstall the support bracket (30) and doors. Secure the pressure hose to the device in an appropriate manner. Connect the mains plug to a properly rated outlet circuit.

A screwdriver must be used to disconnect the cabinet connector if the compressor is being disassembled!
(Fig.6)

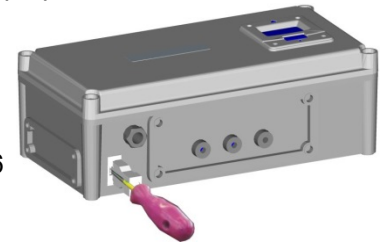

Fig. 6

Cabinet-mounted dental compressor DK50 4VR/50S/M (Fig. 4, Fig. 5)

After removing all packaging material, place the product on the floor and remove stabilization parts X and Y (Detail A). Place the compressor into the cabinet using the procedure defined above. Before the compressor is installed in the cabinet, the hose(s) for the condensate drain (from the dryer and solenoid valve) must be passed through the opening on the back side of the cabinet and connected to the condensate vessel.



The condensate vessel (20) must be on the floor in order to ensure the dryer operates properly. Otherwise the dryer may be damaged.

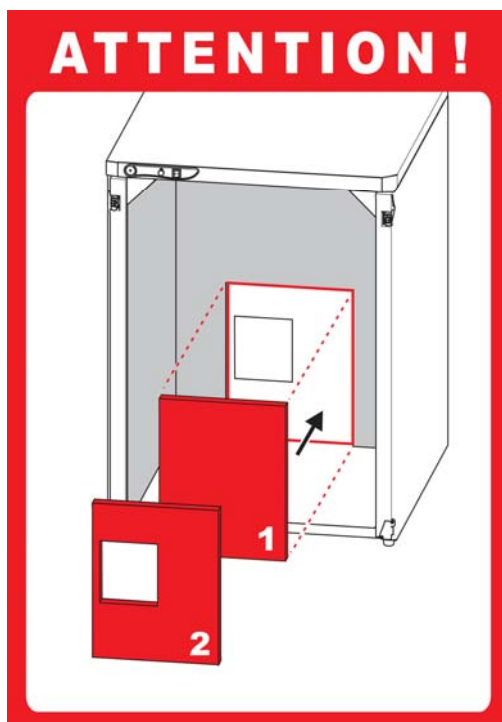

- | | |
|---|-----------------|
| 1 - without dryer | - 061000461-000 |
| 2 - with membrane dryer MD
or NPSL dryer | - 061000463-000 |

Jumper position for DK50 4VR/50(M) and DK50 4VR/50S(M) compressors

The jumper in the compressor wiring box must be properly configured to ensure **DK50 4VR/50(M)** and **DK50 4VR/50S(M)** compressors operate properly. The manufacturer sets the jumper in the proper position for the specific compressor type during production.

If the compressor is converted from **DK50 4VR/50(M)** configuration to **DK50 4VR/50S(M)**, or vice versa, the following steps must be performed:



Prior to any maintenance or repair work, switch off the compressor and disconnect it from the mains (pull out the mains plug).

See chapter „ WIRING DIAGRAMS“ in user manual.



Jumper and blank packaged in the wiring box

A – COMPRESSOR MODIFICATION FROM DK50 4VR/50(M) TO DK50 4VR/50S(M)

- remove jumper Z (jumper off)

- remove jumper Z to eliminate the connection to terminal strip X1 (Fig. a-d)
- connect the cord to socket X2 (Fig.e) / X2, X3 - DK50 4VR/50/M(NDL) (Fig.f). once the compressor is installed in the enclosure

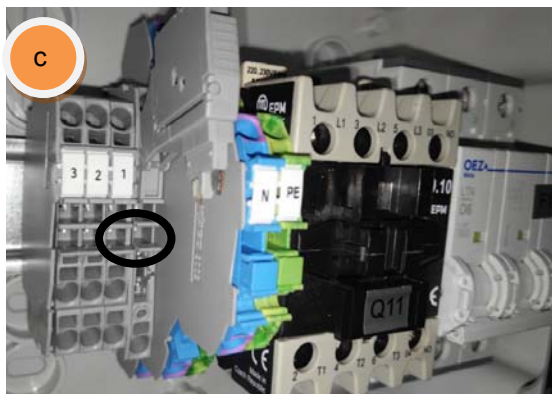
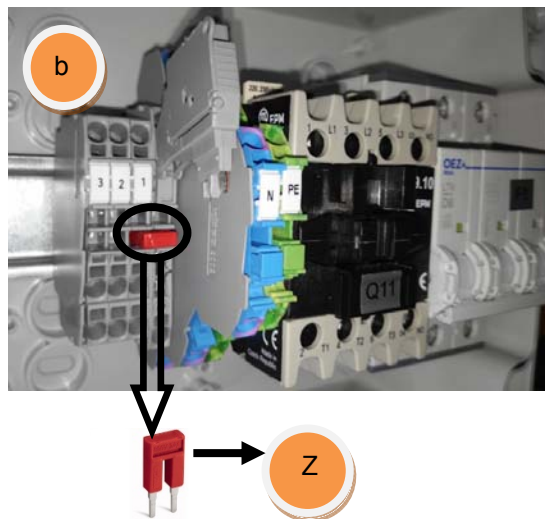

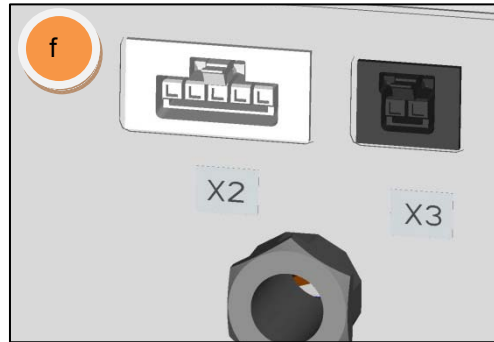

B – COMPRESSOR MODIFICATION FROM DK50 4VR/50S(M) to DK50 4VR/50(M)

- install jumper Z (jumper on)

- use jumper Z (Art. 033190119-000) – to make the connection to terminal strip X1 (Fig. 1-4)
- connect the cord to socket X2 (Fig.5) / X2, X3 - DK50 4VR/50(M)(NDL) (Fig.6) once the compressor is installed in the enclosure

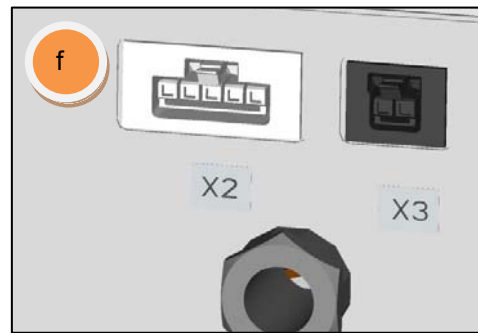
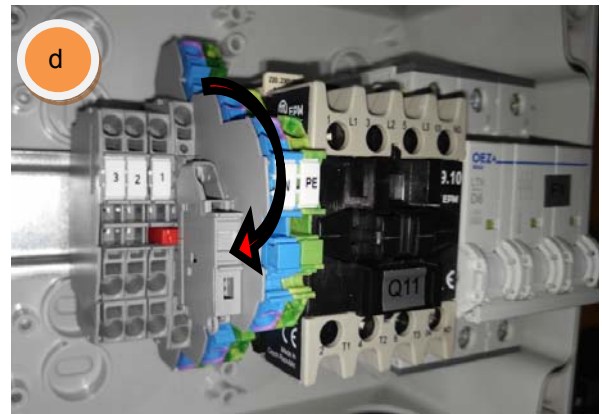
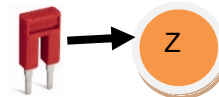
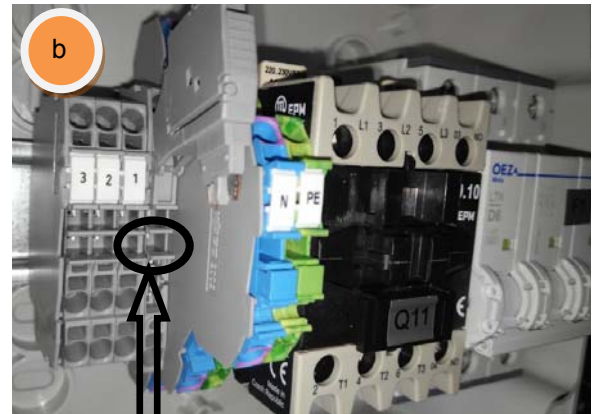
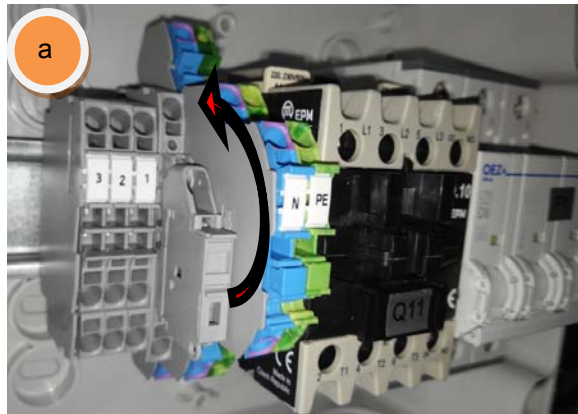

9.2. Compressed air outlet

(Fig.7)

At the compressed air outlet (1) of the compressor, connect the pressure hose. Connect the hose to the appliance.

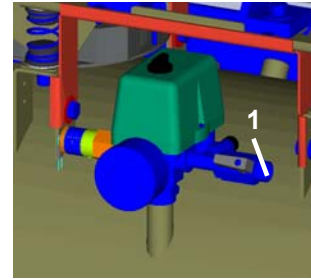

Fig.7

9.3. Electrical connection

Plug the electrical cord into the mains.



The appliance is equipped with a grounded plug. Make sure this connection complies with local electrical codes. The mains voltage and frequency must comply with the data stated on the appliance label.

(Fig.8)

- Keep the socket easily accessible to ensure that in an emergency the appliance can be safely disconnected from the mains.
- Connection to the power distribution box must be max.16 A.
- The connection of the earth ground pin Ø 6mm (1) with other appliances must be completed in accordance with local electrical codes. The female socket (2), which is not included in the standard set, is an optional accessory.



Fig.8



Electrical cable may not contact the hot parts of a compressor. Insulation could be damaged!
If any electrical cord or air hose is damaged it must be replaced immediately.

10. WIRING DIAGRAMS

1/N/PE ~ 230V 50/60Hz
 ELECTRIC OBJECT 1ST CAT.
 TYPE B

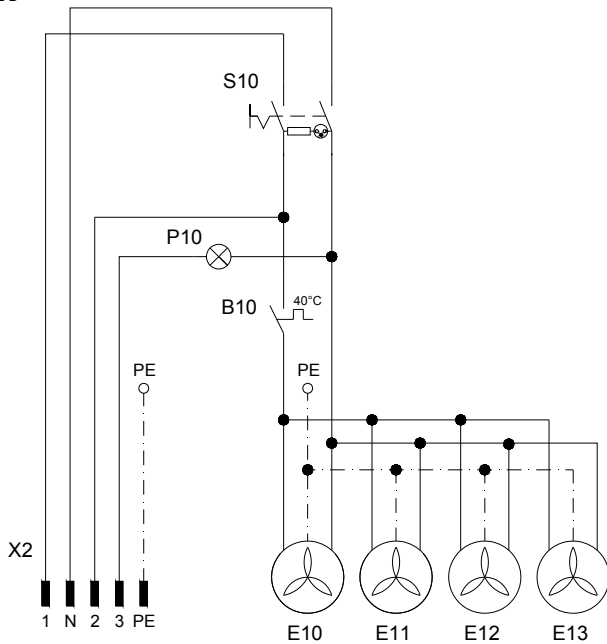

- | | |
|--------------------|----------------------------|
| B10 | Cabinet temperature switch |
| S10 | Switch |
| E10, E11, E12, E13 | Cabinet fan |
| P10 | LED-SERVIS for NDL |
| X2 | Cabinet connector |

SKRINKA S50 4VR

3/N/PE ~ 400 V 50 Hz
 MAINS TN-S [TN-C-S]
 ELECTRIC OBJECT 1ST CAT.
 TYPE B

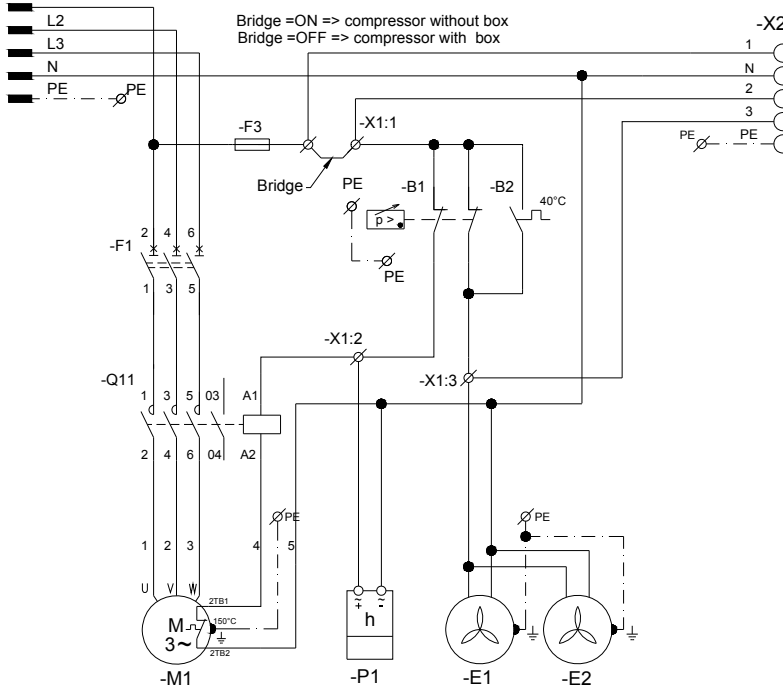

- B1 Pressure switch
- E1, E2 Compressor fan
- B2 Thermo switch
- M1 Compressor motor
- F1 Breaker
- Q11 Contactor
- X1 Terminal strip
- X2 Connector
- F3 Fuse
- P1 Hour counter
- X3 Connector

DK50 4VR/50

3/N/PE ~ 400 V 50 Hz
 MAINS TN-S [TN-C-S]
 ELECTRIC OBJECT 1ST CAT.
 TYPE B

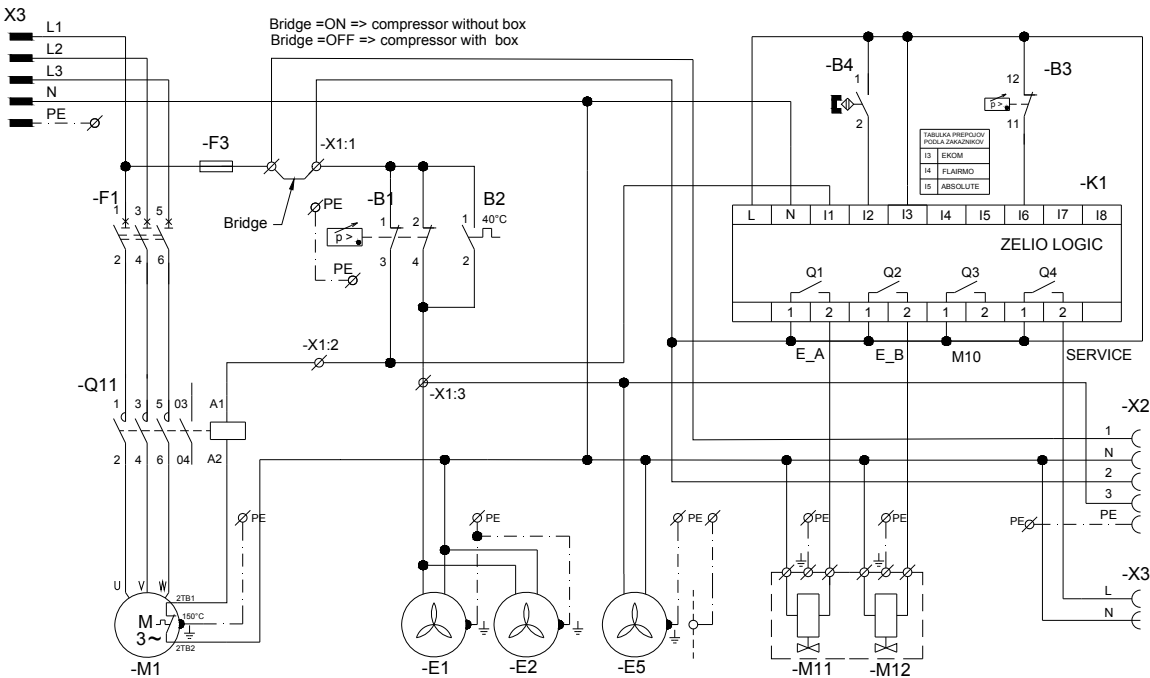

DK50 4VR/50/M (NDL)

- | | | | |
|----------|-----------------------|-----|-------------------|
| B1 | Pressure switch | Q11 | Contacteur |
| E1, E2 | Compressor fan | X1 | Terminal strip |
| E5 | Dryer fan | X2 | Connector |
| B2 | Temperature switch | P1 | Hour counter |
| M1 | Compressor motor | F3 | Fuse |
| F1 | Breaker | K1 | Controller |
| M11, M12 | Solenoid valve, dryer | B4 | Magnetic switch |
| | | B3 | Pressure switch 2 |

3/N/PE - 400 V 50 Hz
 MAINS TN-S (TN-C-S)
 ELECTRIC OBJECT 1ST CAT.
 TYPE B

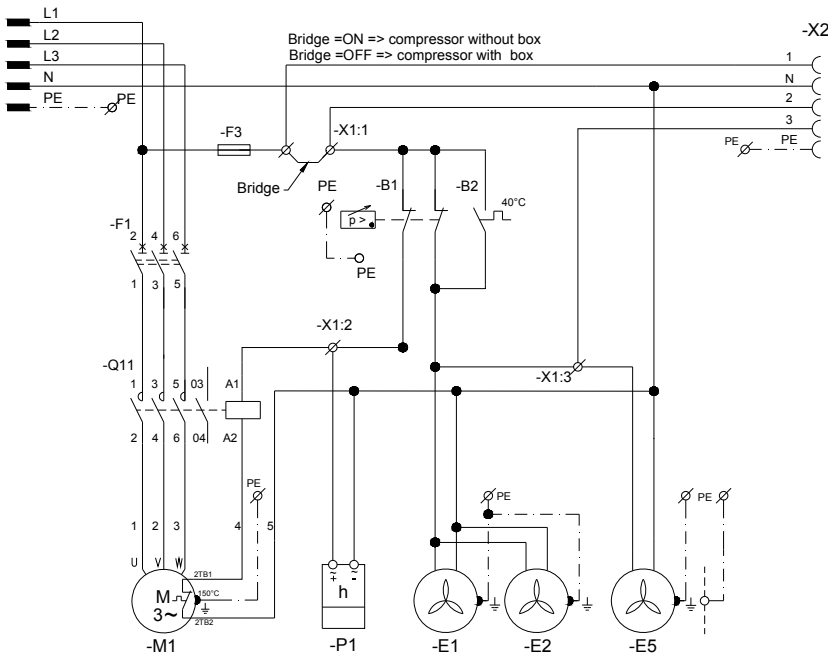

- B1 Pressure switch
- E1, E2 Compressor fan
- E5 Dryer fan
- B2 Temperature switch
- M1 Compressor motor
- F1 Breaker
- F3 Fuse
- Q11 Contactor
- X1 Terminal strip
- X2 Connector
- P1 Hour counter

DK50 4VR/50/M (MD)

11. PNEUMATIC DIAGRAM

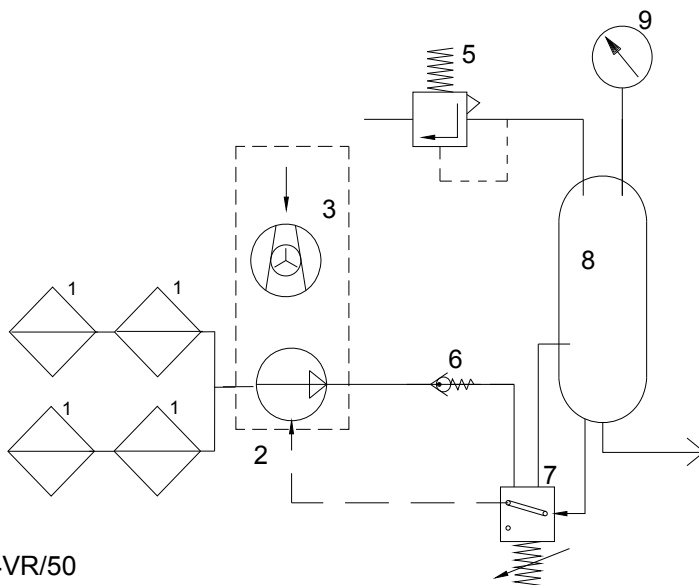

- 1 Inlet filter
- 2 Compressor
- 3 Fan
- 5 Safety valve
- 6 Check valve
- 7 Pressure switch
- 8 Air tank
- 9 Pressure gauge
- 10 Dryer outlet solenoid valve
- 11 Cooler
- 12 Cooler fan
- 13 Condensate separator
- 14 Pressure relief valve
- 15 -
- 16 Dryer
- 17 Jet
- 18 Filter
- 19 Mikrofilter
- 20 Vessel

DK50 4VR/50

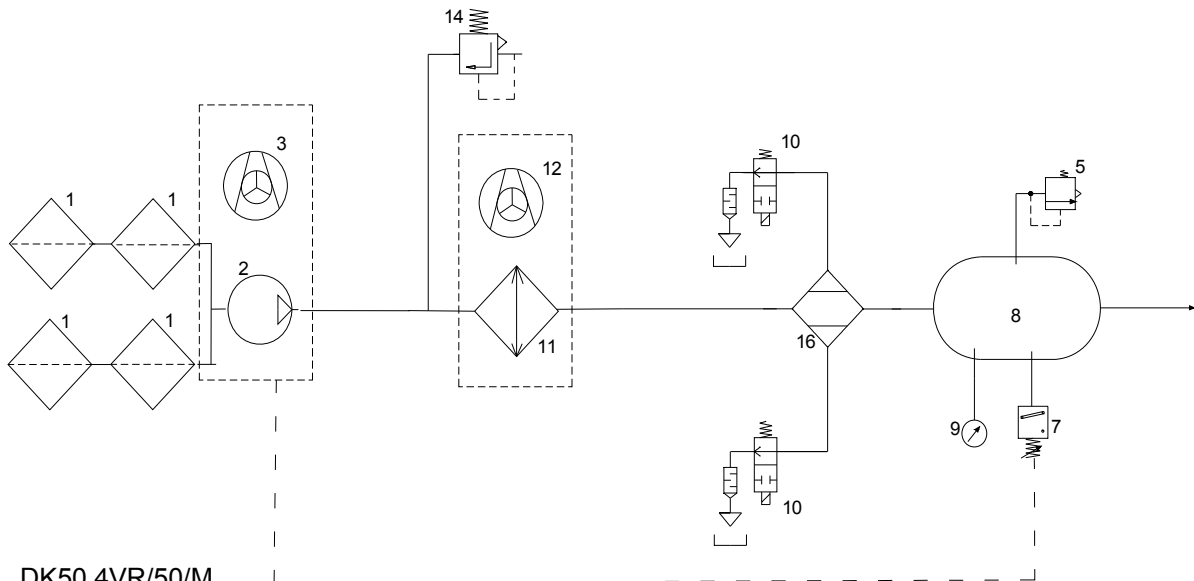
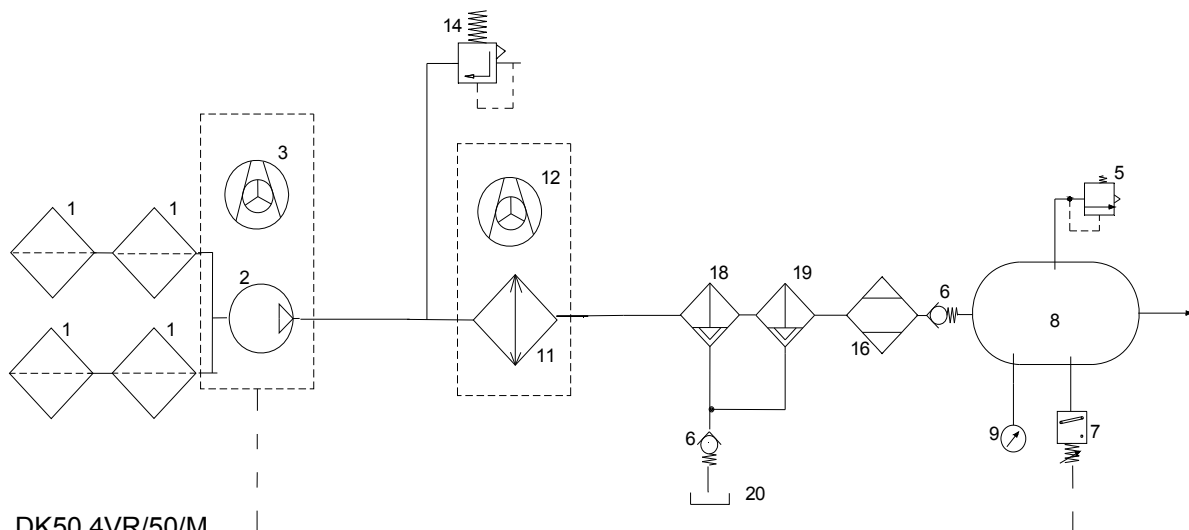
DK50 4VR/50/M
(NDL)DK50 4VR/50/M
(MD)

12. FIRST OPERATION

Make sure that all stabilizers used during transport were removed.

- Check that all pressurized air line connections are secure.
- Connect to the mains.
- Start compressor at pressure switch (2) by turning switch (3) to position "I." (Fig.9)
- For cabinet-mounted compressors, turn the switch (26) in Fig. 4 on the front side of the equipment cabinet into the "I" position; a lighted switch indicates the equipment is in operation.
- **Compressor** - At first operation the air tank is pressurized until it reaches a preset level when the compressor automatically switches off. As the air is used, the compressor works in automatic mode, switched on or off by the pressure switch.
- **Compressor with dryer** – Compressor operation is the same and the moisture from the compressed air is removed as it passes through the dryer.
For NDL - the condensate is also blown out of the drain on the dryer, which can be heard as a brief whoosh sound when the compressor shuts down or when the drying chambers switch.



The compressor is not equipped with an emergency power supply.

OPERATION

In case of emergency, disconnect the compressor from the mains (pull out the mains plug).



The compressor has hot surfaces.
Burns or fire may result if contact is made.



During prolonged operation of the compressor, the temperature in the box may increase to over 40°C. At this point the cooling fan automatically switches on. After cooling the space to under 32°C, the ventilator switches off.



Automatic start: when pressure in the tank drops to the pressure switch's lower limit level, the compressor automatically switches on. The compressor automatically switches off after reaching the pressure switch's upper limit level.

Compressor with dryer

A correct function of the drier depends on the compressor's operation and no attendance is required. The pressure vessel need not be sludged, because the pressure air entering the air chamber is already dried.

- It is forbidden to alter the working pressures of pressure switch set by manufacturer. The operation of the compressor at working pressure lower than the switching pressure demonstrates the overload of the compressor (high air consumption) by the appliance, leakages in pneumatic distributions, failure of aggregate or drier.
- Prior connecting drier to air chamber, that was used with compressor without drier, it is necessary to clean interior surface of air chamber and perfectly remove condensed liquid. Then interconnect electric part of drier with compressor according to wiring diagram in accord with valid regional regulations.



Required drying performance can only be achieved when following the defined operating conditions!



Drying performance will decline and the achieved dew point will drop if the dryer is operated at any pressure below the minimum working pressure!

Dryer operation at a pressure of 0.5 Bar below the minimum working pressure can lower the dew point at the outlet by more than 10°C!



The dryer will be irrevocably damaged and need replacement if operated at any temperature above the maximum working temperature

13. SWITCHING THE COMPRESSOR ON

(Fig.9)

Switch on the compressor at the pressure switch (2) by turning the knob (3) to position "I." (for compressor in the box switch (26) Fig.4), on the front part of the compressor box), The compressor sends pressurized air to the air tank. As the compressed air is used, the pressure in the air nozzle drops to a preset level, the compressor switches on and the air nozzle fills with compressed air. After reaching the cutoff pressure the compressor turns off automatically and the cycle is repeated. Check the value of switching-on and switching-off pressure on pressure gauge. The values may be within a tolerance of $\pm 10\%$. Air pressure in air chamber must not exceed maximal permitted operation pressure.

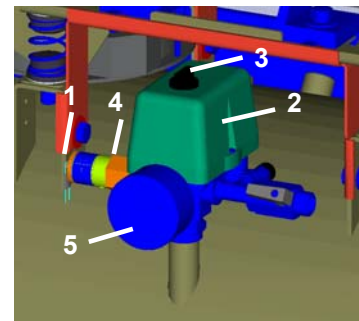
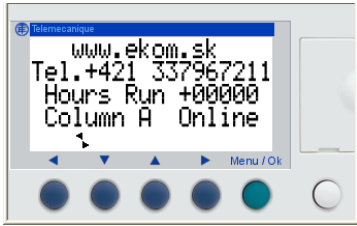

Fig.9



Never tamper with the pressure switch (2). Adjustments are not allowed. The pressure switch (2) has been set by the manufacturer and further setting of switching on and off pressure may be carried out only by a qualified expert trained by the manufacturer.

CONTROL PANEL SCREENS FOR THE NDL DRYER



- Supplier
- Supplier contact
- Operating hours
- Chamber A (B) in operation

Status messages

- **Low pressure**

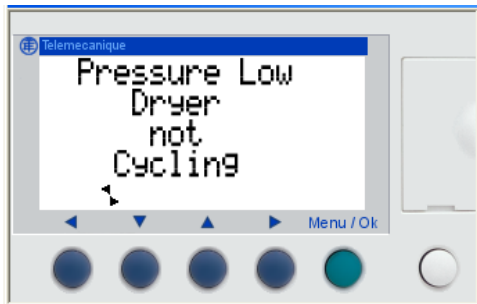

- a) From compressor start-up until pressure reaches 5.5 bar
- b) During operation if pressure drops below 5.1 bar

- **24-hour regeneration mode**

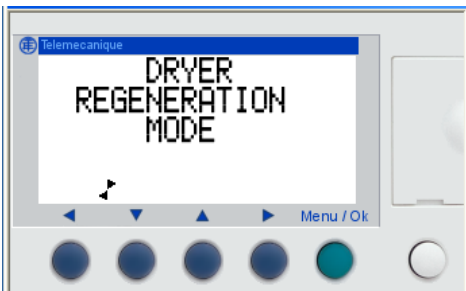

Dryer regeneration for 10 minutes is automatically switched on after 24 hours of compressor operation.

- **2 year maintenance**

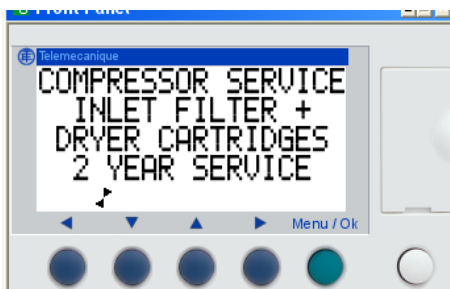

Calculated when equipment is switched on

- **8,000 hour maintenance**

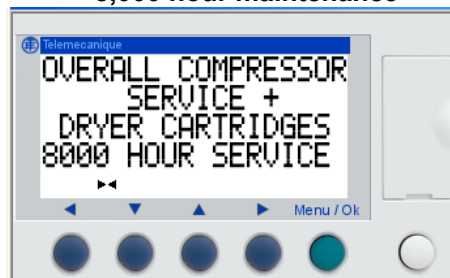

Calculated using the number of operating hours

MAINTENANCE**14. MAINTENANCE SCHEDULE*****Notice!***

The operating entity is obliged to ensure that all tests of the equipment are carried out repeatedly at least once within every 24 months (EN 62353) or in intervals as specified by the applicable national legal regulations. A report must be prepared on the results of the tests (e.g.: according to EN 62353, Annex G), including the measurement methods used.

Time interval	Maintenance that must be performed	Chapter	Performed by
1 x day	Emptying condensate At high air humidity	15.2	User
1x per week	Compressors without air dryers		
1x per week - check function	Compressors with air dryers		
Once annually	Equipment cleaning	15.1	Qualified technician
	Check of dryer function	15.3	
	Safety valve check	15.4	
	MD Replace filter and micro-filter elements	15.6 15.7	
	Check tightness of joints and overall inspection of the equipment	Maintenance documentation	
	• Clean the cooler ribs and the fan	15.9	
1 x every 2 years	Conduct "repeated test" pursuant to EN 62353	14	
1 x every 2 years or after 5000 hours	Replace inlet filter and pre-filter	15.5	
	NDL Replacement maintenance kit - dryer	15.8	
8,000 hours (or 2 years)	Replace media in both dryer cylinders and seals.		
16,000 hours (or 4 years)	Replace media in both dryer cylinders and seals.		
24,000 hours (or 6 years)	Replace media in both dryer cylinders, seals and all valves.		

15. MAINTENANCE

Repair work beyond normal maintenance can be performed only by qualified personnel or the manufacturer's representative.
Use only spareparts and accessories approved by the manufacturer.



Prior to any maintenance or repair work, switch off the compressor and disconnect it from the mains (pull out the mains plug).

TO ENSURE THAT THE COMPRESSOR WORKS CORRECTLY, PERFORM THE FOLLOWING MAINTENANCE TASKS AT REGULAR INTERVALS (CHAPTER 14)::



THE CABINET MUST BE OPENED ON CABINET-MOUNTED COMPRESSORS BEFORE CONDUCTING THE FOLLOWING CHECKS.

15.1. Equipment cleaning

The equipment, in particular the cooling fan must be kept clean to ensure the long-term efficiency of the cooler – the cooling fins must be cleaned occasionally to remove any dust.

15.2. Condensation drain valve

Compressors (Fig.10)

Switch off the compressor at the mains. Reduce air pressure in the appliance to max. 1 bar by releasing air via a connected device. Place the vessel under release valve (1) and open it. Wait until condensation is fully drained from the pressure tank. Close drain valve (1).

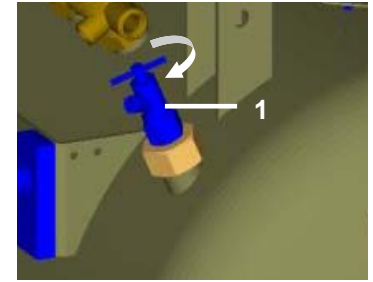

Fig.10

Compressors with air dryer

In the case of a regular operation condensate is automatically excreted via air dryer and it is entrapped in a bottle. Take out the bottle from a holder, release cap and pour out the condensate.

15.3. Check of dryer function

Check for proper dryer function by opening the vent valve. No condensate should leak out. Seek professional assistance if condensate appears during such venting!

15.4. Safety valve check

(Fig.9)

When the compressor is operated for the first time, make sure that the safety valve is working properly. Turn screw (4) of safety valve (1) several rotations to the left until the safety valve releases air. Let the safety valve blow out for only a few seconds. Turn screw (4) to the right until it seats, closing the valve.



The safety valve must never be used for depressurizing the air tank. It could damage the safety valve. The valve is set to the maximum permitted pressure by the manufacturer. Adjustments are not permitted.



Warning! Compressed air can be dangerous. Wear eye protection when blowing air out.

15.5. Replacement of the inlet filter and prefilter

(Fig.11)

At the lid of the compressors crankcase is an Inlet filter (1) and prefilter (3).

Replacing of the inlet filter:

- Hand pull the rubber stopper (2).
- Remove used and dirty filter.
- Input new filter and set rubber stopper.

Replacing of the prefilter:

- Hand pull prefilter (3).
- Replace old prefilter with new

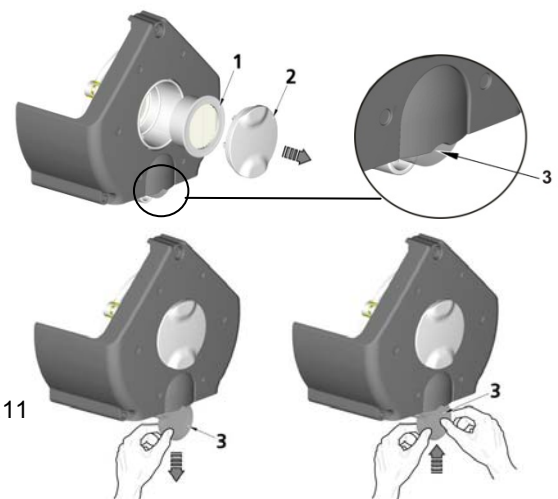

Fig.11

	Order number
Input filter	025200139-000
Prefilter	025200150-000

15.6. Replace the filter element

(Fig. 12)

Release the catch (1) on the filter vessel by pulling down.
 Rotate the vessel (2) and remove.
 Unscrew the filter retainer (3).
 Replace the filter element (4) and reinstall the filter retainer.
 Reinstall the filter vessel and rotate to secure against the catch.



Fig. 12

Filter	Order number	Filter element	Order number
AF40-F03C-6-A-PU	025200288-000	AF 40P-060S 5 µm	025200079-000

15.7. Replacing the micro-filter element

(Fig. 13)

Release the catch (1) on the micro-filter vessel by pulling down.
 Rotate the vessel (2) and remove.
 Remove the filter (3).
 Install the new filter element.
 Reinstall the filter vessel and rotate to secure against the catch.



Fig. 13

Micro-filter	Order number	Filter element	Order number
AFM40-F03C-6-A-PU	025200289-000	AFM 40P-060AS 5 µm	025200080-000

15.8. NDL dryer maintenance kit replacement

Before starting any work, disconnect the equipment from all power sources and vent the air tank to zero

Repair work beyond normal maintenance can only be performed by qualified personnel or the manufacturer’s representative.

The maintenance kit contains: Cartridge with drying media, gaskets and valves depending on maintenance interval.

An indicator indicates maintenance interval :

- on the display - Zelio Logic
- on the cabinet

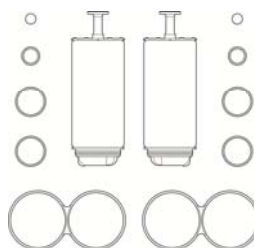

Fig.14-A: Spare parts

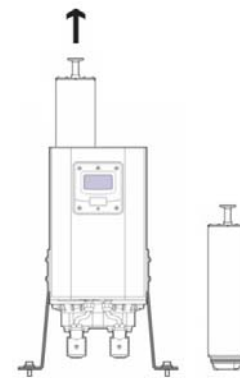

Fig.14-B: Dryer cartridge

Dryer	Order number	Dryer service kit	Order number
NDL-30	035900093-000	NDK-30	

15.9. Clean the cooler ribs and the fan

For permanently high efficiency, it is necessary to maintain the whole equipment and especially the cooler’s fan and the cooler itself clean – 1x year suck or blow settled dust out with compressed air from the surface of the cooling ribs and the fan.

16. STORAGE

If the compressor will not be used for a prolonged time period, drain any condensate from the air tank. Then turn on the compressor for 10 minutes, keeping the drain valve open (1) (Fig.10). Switch off the compressor by switch (3) at pressure switch (2) (Fig.9), close the drain valve and disconnect the appliance from the mains.

17. DISPOSING OF THE APPLIANCE

- Disconnect the appliance from the mains.
- Release air pressure in the pressure tank by opening the drain valve (1) (Fig.10).
- The components of the product are non-toxic.
- Dispose of the appliance following all environmental regulations.

18. REPAIR SERVICE

Guaranteed and post-guarantee repairs must be done by the manufacturer, its authorized representative, or service personnel approved by the supplier.

The manufacturer reserves the right to make changes to the appliance without notice. Any changes made will not affect the functional properties of the appliance.

19. SOLVING PROBLEMS



Caution! Before proceeding, depressurize the air tank to zero and disconnect the appliance from the mains.

The internal surfaces of the air tank must be cleaned and all condensed liquid must be removed after a dryer failure.

Check the dew point of the air leaving the air tank (see Chapter 5 - Technical Data) in order to protect connected equipment from damage!

Troubleshooting can be performed only by qualified personnel.

FAILURE	POSSIBLE CAUSE	REMEDY
Compressor does not start	No voltage in pressure switch Disconnected winding of motor, damaged thermal protection Faulty capacitor Seizure of piston or another rotary part Pressure switch does not switch on	Check voltage in socket Check fuse – replace faulty one Loosen terminal – tighten it Check power cord – replace faulty one Replace motor or re-wind it Replace capacitor Replace damaged parts Check the function of pressure switch
Compressor often switches on	Air leak in pneumatic distribution system Leaking check valve Greater volume of condensed liquid in pressure vessel	Check pneumatic distribution system – seal loose joint Clean valve, replace seals, replace valve Drain condensed liquid
Prolonged running of compressor	Air leak in pneumatic distribution system Worn piston ring Contaminated input filter and prefilter Dirty filter in the dryer Defective solenoid valve	Check pneumatic distribution system – seal loose joint Replace worn piston ring Replace contaminated filters with the new ones Change the outlet filter and inspect dessicant Repair or change the valve
Compressor is noisy (knocking, metal noises)	Damaged bearing of piston, piston rod, motor bearing Loose or cracked spring	Replace damaged bearing Replace damaged spring
Dryer doesn't dry (condensed water in the tank)	Membrane dryer	
	inoperative cooler ventilator	replace ventilator check supply of electric energy
	Damaged dryer	Replace dryer
	Dirty automatic condensate drain on filters	clean / replace
	Dirty filter and micro-filter elements	Replace old elements with new elements
	NDL Dryer	
Decreased dew point performance	1. Insufficient pressure at inlet 2. Electrical failure 3. Damp or contaminated dryer media 4. Excessively high air consumption 5. Excessive inlet air temperature 6. Insufficient clean air 7. Exhaust silencer blocked	1. Inlet pressure must be at least 4 Bar. If this is not the case, adjust and set the inlet pressure. 2. Ensure the equipment is switched on and the dryer's front panel is lit, check for proper dryer cycle. 3. Remove the source of the contamination. Replace the cartridges – do not reuse. 4. Ensure dryer performance matches required air demand. 5. Check technical specifications. 6. Cancel incorrect settings and contact a service technician – adjust settings. 7. Contact a service technician.
Dryer cycle failure	8. Controller malfunction 9. Lamp is not lit 10. Insufficient inlet pressure 11. Venting malfunction during regeneration 12. Output flow halted	8. Check to ensure controller has power, check the display to ensure the solenoid valves are powered in regular cyclical operation. 9. Check unit power and fuses 10. Inlet pressure must be at least 4 Bar. If this is not the case, adjust and set the inlet pressure. 11. If the solenoid valve has power and is malfunctioning – replace the valve. The valve is working properly if a click can be heard at the outlet when venting 12. Check the air flow at the inlet.
Constant venting	13. Dryer run failure 14. Irregular air flow from exhaust	13. Switch off and restart the dryer. Check to see if the dryer is under pressure before switching on – to ensure the dryer can be started before starting operation. 14. Defective or damaged valve, maintenance required



DK50 4VR/50

for four dental units
für vier Dentaleinheiten



PRODUCENT:
HERSTELLER:
ПРОИЗВОДИТЕЛЬ:
VÝROBCA:
VÝROBCE:

EKOM spol. s r.o.
Priemyselná 5031/18
921 01 PIEŠŤANY
Slovenská republika
tel.: +421 33 7967255
fax: +421 33 7967223
e-mail: ekom@ekom.sk
www.ekom.sk